

804

D4

805

D4

Welcome and thank you for choosing

Bowers & Wilkins. Our founder, John Bowers, believed that imaginative design, innovative engineering and advanced technology were keys that could unlock the enjoyment of audio in the home. His belief is one that we continue to share and inspires every product we design.

The 800 Series Diamond is the world's most advanced range of loudspeakers. Each model benefits from thoughtful installation, so we would suggest that you take some time to read this manual before you begin the installation process. **Continue to page 4 →**

Bienvenido a Bowers & Wilkins. Gracias por elegir

Bowers & Wilkins. John Bowers, nuestro fundador, estaba firmemente convencido de que el diseño imaginativo, la ingeniería innovadora y la tecnología avanzada eran las claves a la hora de llevar el disfrute del sonido a la intimidad del hogar. Una creencia que seguimos compartiendo y que inspira todos y cada uno de los productos que diseñamos.

La Serie Diamond 800 es la gama de cajas acústicas más avanzada del mundo. Cada uno de los modelos que la constituyen se beneficiará de una instalación a conciencia, por lo que le sugerimos que antes de llevarla a cabo se tome su tiempo para leer este manual.

Continúa en la página 16 →

Welkom en dank u voor het kiezen van Bowers & Wilkins.

Onze oprichter John Bowers, was ervan overtuigd dat een fantasievol ontwerp, innovatieve techniek en moderne technologie de sleutels vormden tot muziekbeleving thuis. Het is deze overtuiging waar we nog steeds van uitgaan en die de inspiratie vormt voor elk product dat we ontwerpen.

De 800 Serie Diamond is 's werelds meest geavanceerde model luidsprekers. Elk model is voorzien van een slimme installatiemethode en daarom raden we u aan dat u de tijd neemt om deze handleiding te lezen voordat u aan het installeren begint. **Lees verder op pagina 28 →**

Bienvenue et merci d'avoir choisi Bowers et

Wilkins. Lorsque John Bowers a créé sa société, il savait déjà qu'un design imaginatif, une conception innovante et une technologie avancée seraient les clés du plaisir de l'écoute de la musique à domicile. C'est cette philosophie qui, aujourd'hui, continue de nous inspirer pour la conception de chaque nouvel appareil.

La 800 Series Diamond est la gamme d'enceinte acoustique la plus avancée au monde. Chaque modèle bénéficiera d'une mise en œuvre soignée, aussi nous vous suggérons de prendre le temps de lire ce manuel avant d'en commencer l'installation. **Suite page 8 →**

Bem-vindo e obrigado por escolher a Bowers &

Wilkins. O nosso fundador, John Bowers, acreditava que um design criativo, engenharia inovadora e tecnologia avançada eram as chaves que poderíamos abrir portas para se desfrutar de áudio em casa. A sua crença é algo que continuamos a partilhar e que inspira cada produto que concebemos.

A Série 800 Diamond é a gama mais avançada de colunas, a nível mundial. Cada modelo tira partido de uma instalação cuidadosa, pelo que recomendamos que leia este manual antes de iniciar o processo de instalação. **Continuação na página 20 →**

Καλώς ήρθατε και ευχαριστούμε που επιλέξατε την

Bowers & Wilkins. Ο ιδρυτής μας, John Bowers, πίστευε ότι η ευφάνταστη σχεδίαση, η καινοτομία στην ανάπτυξη και η εξελιγμένη τεχνολογία θα ήταν τα κλειδιά που θα άνοιγαν νέους κόσμους απόλαυσης του ήχου στο σπίτι. Αυτή την πίστη του συνεχίζουμε να μοιραζόμαστε και αυτή εμπνέει κάθε προϊόν που σχεδιάζουμε.

Η 800 Series Diamond είναι η πιο εξελιγμένη σειρά ηχείων στον κόσμο. Κάθε μοντέλο επωφελείται από την προσεκτική εγκατάσταση, οπότε θα προτείναμε να αφιερώσετε λίγο χρόνο στην ανάγνωση αυτού του εγχειριδίου προτού ξεκινήσετε τη διαδικασία εγκατάστασης. **Συνέχεια στη σελίδα 32 →**

Willkommen bei Bowers & Wilkins.

Der Firmengründer John Bowers war der Meinung, dass ein wunderschönes Design, eine innovative Konstruktion und ausgeklügelte Technologien die Schlüssel zu Audio-Entertainment der Extraklasse in Ihrem Zuhause sind. Wir teilen seine Meinung und jedes von uns entwickelte Produkt basiert darauf.

Die Modelle der 800 Serie Diamond gehören zu den besten Lautsprechern weltweit. Ihre Installation sollte gut durchdacht werden. Wir empfehlen daher, sich die Zeit zu nehmen und diese Bedienungsanleitung vor der Installation zu lesen. **Fortsetzung auf Seite 12 →**

Benvenuti e grazie per aver scelto un prodotto

Bowers & Wilkins. Il nostro fondatore, John Bowers, era convinto che design attraente, capacità d'innovare e tecnologie all'avanguardia fossero fattori vincenti per la riproduzione audio domestica. Le sue idee sono ancor oggi condivise da noi tutti e fonte d'ispirazione per ogni nuovo modello che progettiamo.

I modelli della Serie 800 Diamond sono tra i più avanzati diffusori al mondo e meritano quindi di venir installati in maniera scrupolosa. Vi suggeriamo pertanto di leggere attentamente questo manuale prima di iniziare. **Continua a pagina 24 →**

Добро пожаловать и благодарим вас за приобретение

продукта компании Bowers & Wilkins. Наш основатель, Джон Бауэрс, верил в то, что творческий подход в проектировании, новаторская конструкция и передовые технологии смогут открыть людям путь к подлинному звучанию в доме. Мы продолжаем разделять его веру, и она вдохновляет нас при проектировании всех новых продуктов.

Серия 800 Diamond – это самые совершенные в мире акустические системы. Каждая модель может получить преимущества от продуманной установки, поэтому мы рекомендуем вам уделить некоторое время на прочтение этого Руководства перед тем как начать процесс установки. **Продолжение на стр. 36 →**

Vítejte u Bowers & Wilkins. Děkujeme Vám, že jste si zvolili značku Bowers & Wilkins. Když John Bowers zakládal naši firmu věřil, že nápadité provedení, novátorský přístup a pokročilé technologie jsou klíčem otevírajícím dveře kvalitní reprodukci. Touto filozofií se dodnes inspirováme, kdykoli tvoříme nový produkt.

Reprosoustavy řady 800 Diamond jsou jedněmi z nejvíce sofistikovaných reprosoustav na světě. Pro každý z modelů je však důležitá jeho správná instalace. Dříve než začnete, věnujte tedy prosím trochu času přečtení tohoto manuálu. **Pokračujte na stranu 40 →**

Hoş geldiniz ve Bowers & Wilkins'ı seçtiğiniz için teşekkür ederiz. Kurucumuz John Bowers, yaratıcı tasarımının, yenilikçi mühendisliğin ve ileri teknolojinin, evde sesin keyfini çıkarmanın kilidini açacak anahtarlar olduğuna inanıyordu. O'nun inancının paylaşmayı sürdürmekteyiz ve bu inanç, tasarladığınız her ürüne ilham vermektedir.

800 Diamond serisi, dünyanın en gelişmiş hoparlörleri sınıfındadır. Her bir model, dikkatli kurulum gerektirmektedir, bu nedenle kurulum işlemine başlamadan önce bu kullanma kılavuzunu okumaya zaman ayırmanızı öneririz. **Devamı Sayfa 52'te →**

Bowers & Wilkins製品をお買い上げいただき、ありがとうございます。B&Wの創業者であるJohn Bowersは、創意に富んだデザインと革新的な工業技術、そして先進技術が、家庭でもオーディオを十分に楽しむ鍵であると信じていました。現在でも彼の信念はB&Wで共有されており、この信念はB&Wが設計するすべての製品に命を吹き込んでいます。

800シリーズ・ダイヤモンドは世界最先進クラスのスピーカーです。慎重な据え付けを行うことによって各モデルの持ち味が発揮されます。設定する前にこのマニュアルをよく読んでください。**64ページに続く →**

Köszönjük, hogy a Bowers & Wilkins-t választotta.

Amikor John Bowers megalapította a társaságot, célja az volt, hogy az ötletes dizájn, innovatív megoldások és fejlett technológia révén tökéletesítse az otthoni hangzásvilág élményét. Ez az elképzelés mai napig a vállalat mozgatórugója, amely minden termékünk tervezését meghatározza.

A 800 Diamond sorozat a világ legfejlettebb hangsugárzóiból áll. Mindegyik modell beüzemelése nagy odafigyelést igényel, ezért javasoljuk, hogy szánjon egy kis időt ennek az útmutatónak az elolvasására.

Folytatódik a 44.oldalon →

欢迎并感谢您选购 Bowers & Wilkins 产品。

我们的创办人John Bowers先生相信充满想象的设计、创新的工程和先进的技术是开启家庭音响娱乐大门的重要元素。我们依然坚持着他的信念，并赋予我们所有产品设计灵感。

800 Diamond系列是世界上最先进的扬声器系列。周详的安装可使扬声器发挥最佳音效，因此我们建议在开始安装过程前，请花一些时间阅读本手册。

第 56 页(续) →

Bowers & Wilkins 제품을 구매하여 주신데 대해 깊이 감사 드립니다.

Bowers & Wilkins의 창립자 John Bowers는 가정에서 오디오의 즐거움을 느끼게 하는 중요 요소는 창의력이 풍부한 디자인, 혁신적 엔지니어링과 고도의 기술이라고 확신하였습니다. 그의 신념은 현재도 Bowers & Wilkins에서 공유되고 있으며 Bowers & Wilkins가 설계하는 모든 제품에 생명을 불어 넣고 있습니다.

800 시리즈 다이아몬드는 성능이 매우 뛰어난 스피커로서 설치하는데 세심한 주의가 필요합니다. 사용하기 전에 이 매뉴얼을 잘 읽어 보시기 바랍니다.

68쪽에 계속 →

Witamy i dziękujemy za wybór produktu Bowers & Wilkins.

John Bowers założył swoją firmę, ponieważ wierzył, że ciekawy wygląd, innowacyjna konstrukcja i zaawansowana technologia są kluczem do rozkoszowania się dźwiękiem w domowym zaciszu.

Seria 800 Diamond jest najbardziej zaawansowanym asortymentem głośników na świecie. Przemysłana instalacja pozwala na uzyskanie pełni możliwości każdego modelu serii, dlatego też sugerujemy abyście poświęcili Państwo chwilę na przeczytanie niniejszej instrukcji przed rozpoczęciem użytkowania. **Więcej na stronie 48 →**





歡迎並感謝你選購 Bowers & Wilkins 產品。我們的創辦人John Bowers先生相信充滿想像的設計、創新的工程和先進的技術是開啟家庭音響娛樂大門的重要元素。我們依然堅持著他的信念，並賦予我們所有產品設計靈感。

800 Diamond系列是世界上最先進的揚聲器系列。周詳的安裝可使揚聲器發揮最佳音效，因此我們建議在開始安裝過程前，請花一些時間閱讀本手冊。**第60**

頁(續) →

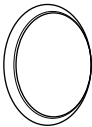
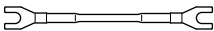
1. Unpacking

805 D4

	2
	4
	8
	2
	1

Carton Contents

805 D4

- 2 Grilles
- 4 Terminal link wires
- 8 Self-adhesive plastic pads
- 2 Two-part foam plugs
- 1 Cleaning cloth

804 D4

- 2 Midrange grilles
- 4 Bass grilles
- 4 Terminal link wires
- 8 Spikes
- 8 Rubber feet and lock nuts (fitted to the speaker)
- 1 Metal spike adjustment bar
- 1 Lock nut adjustment tool
- 1 Cleaning cloth

The 805 D4 and 804 D4 are very heavy and we strongly suggest that they are unpacked in the room in which they are to be used by two people working together. It is also a sensible precaution to remove jewellery to negate the risk of scratching the speakers' surface finish.

The tables above illustrate the component parts that are packed with the 805 D4 and 804 D4. In the unlikely event that anything is missing please contact the retailer from whom you purchased the speakers.

804 D4

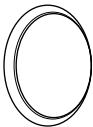
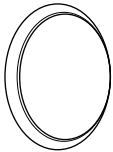
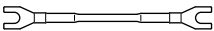
	2
	4
	4

The heavier bass/midrange grilles attach magnetically and are packed in a separate compartment to prevent movement in transit.

Note: Care must be taken when fitting or removing the magnetically attached grilles to avoid marking the product. The grilles will mark the speaker / stand plinth if dropped; you can mitigate against this by covering the plinth when fitting or removing the grilles.





Tweeter diaphragms are very delicate and easily damaged. In the 800 Series Diamond we include a steel grille mesh that can protect the tweeter from many forms of damage. However, you should still exercise care when handling and cleaning your loudspeakers.

Environmental Information

This product complies with international directives, including but not limited to:

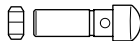
- i. the **R**estriction of **H**azardous **S**ubstances (RoHS) in electrical and electronic equipment,
- ii. the **R**egistration, **E**valuation, **A**uthorisation and restriction of **C**hemicals (REACH)
- iii. the disposal of **W**aste **E**lectrical and **E**lectronic **E**quipment (WEEE).

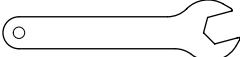
Consult your local waste disposal authority for guidance on how properly to recycle or dispose of this product.

	8
	8
	1
	1
	1

The tweeter assembly on this 800 Series Diamond loudspeaker is a decoupled component that is mechanically isolated from the main part of the cabinet. As such, it may appear to be loose when the product is first removed from its packaging. This is not a fault: it is an inherent feature of the design and ensures optimum performance from your speaker.

If the tweeter assembly has moved slightly during transit and requires adjustment, the assembly can be moved very slightly forwards and backwards to ensure that the rear of the tweeter body is aligned with the rear of the speaker cabinet. The tweeter assembly can also be rotated very slightly to ensure that the Bowers & Wilkins logo is vertically orientated. Do not force the tweeter into any position beyond the soft end-stops when making these adjustments.

Note: Care must be taken to not damage the decoupling assembly when making these adjustments - please seek assistance from your dealer if you are in any doubt about adjusting the tweeter assembly.

2. Positioning

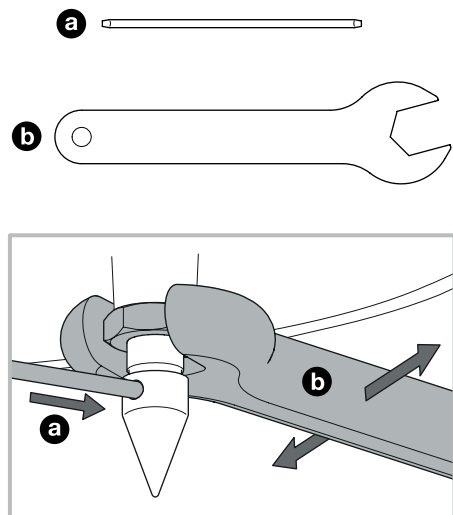

FS-805 D4 or 804 D4

FS-805 D4 and 804 D4 are intended to be floor mounted only. It is important to ensure that they stand firmly on the floor using the spike feet supplied whenever possible.

FS-805 D4 and 804 D4 are supplied with both spikes, (intended for mounting the speaker on a carpeted floor) and rubber feet (intended for mounting the speaker on a hard floor).

Note: If the spikes are used on a hard floor, it is advisable to place a hard protective surface between the spikes and the floor to ensure that the floor is not marked by the spike.

In order to stabilise the speaker, initially fully screw the lock nuts onto the spikes/rubber feet. Then screw the spikes/rubber feet fully into the threaded inserts in the base of the speaker/stand. If the speaker/stand rocks when placed on the floor, unscrew the spikes/rubber feet that do not touch the floor until the speaker/stand rests firmly without rocking. Finally lock the nuts against the base by using the supplied tool to gently tighten the nut whilst using the supplied bar to stop the spike/rubber foot rotating.

Note: Take care not to mark the finish of the speaker plinth or stand base when using the adjustment tools.

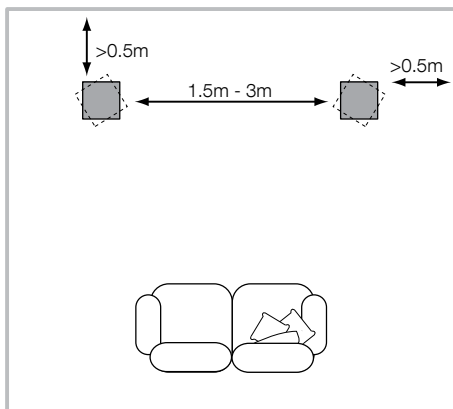

It may be more convenient to fit and adjust the spikes/rubber feet after speaker positioning has been optimised in the room. If fitting or exchanging the spikes/rubber feet, after removing the speaker from its packaging, the speaker can be carefully lowered onto its side to ease access to the underside of the base. It is advisable to place the speaker on a soft, non-marking surface when lowering it to ensure that the surface finish is not damaged. Once the spikes/rubber feet are fitted, the speaker can be lifted into position.

Note: It is advisable that two people work together to lift the product due to its weight. The speaker should not be dragged across the floor once the spikes/rubber feet have been installed as this is likely to result in damage to both the speaker and the floor.

Speaker Installation Using Wall Shelves (805 D4 only)

The speaker is primarily designed to be mounted on a dedicated floor stand (FS-805 D4), but may be placed on a shelf, although this offers less flexibility to optimise the speaker's performance. If shelf placement must be used, we recommend using the foam bung inserts (supplied) to optimise port performance (see Fine-Tuning). In both installation cases, the speakers' tweeters should be approximately at ear height at your usual listening position.

Note: If using a shelf, ensure that it is strong enough to properly support the weight and fit the 4 self-adhesive plastic feet to the underside of the speaker.

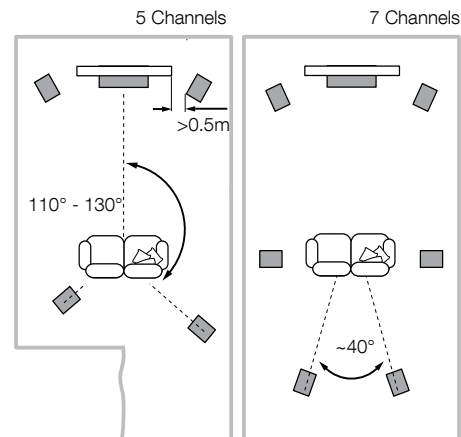

Speaker Positioning

In either stereo or home theatre installations, try to ensure that the immediate surroundings of each speaker are similar in acoustic character. For example, if one speaker is adjacent to bare walls while the other is adjacent to soft furnishings and curtains, both the overall sound quality and the stereo image are likely to be compromised.

Conventional Stereo Systems

To begin with, the speakers should be positioned between 1.5m and 3m apart at two corners of an equilateral triangle completed by the listening area at the third corner. The speakers should be placed at least 0.5m away from the back and any side walls (as per the illustration above).

Home Theatre Systems

If the speakers are to be used for the front channels in a home theatre system, they should be placed closer together than for 2-channel audio, because the surround channels tend to widen the image. Positioning the speakers within approximately 0.5m of the sides of the screen will also help keep the sound image in scale with the visual image. As with conventional stereo positioning, the speakers should ideally be at least 0.5m away from any side walls.

3. Connections

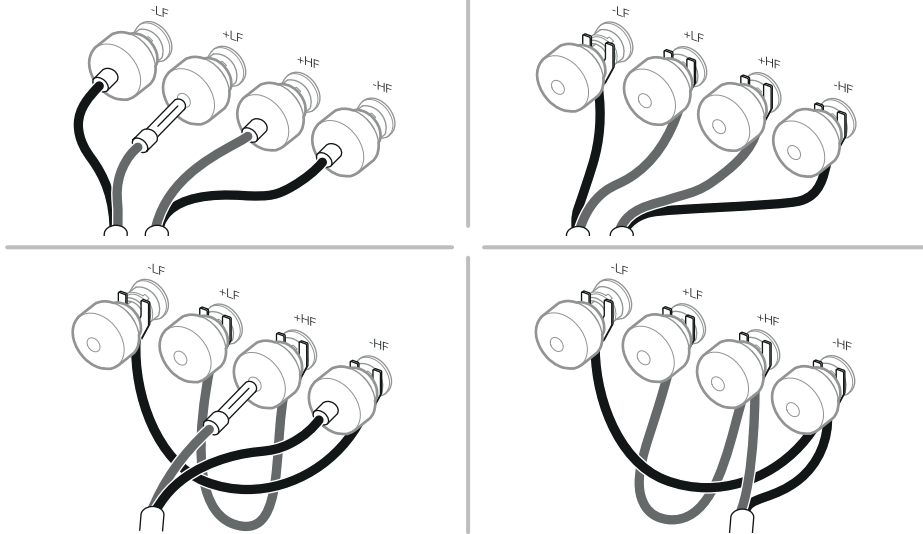

Important Safety Notice

All connections should be made with the audio equipment switched off. When using audio equipment in normal operation, touching uninsulated speaker terminals or wiring may result in an unpleasant sensation.

The 805 D4 and 804 D4 speaker terminals accept a variety of cable terminations: 4mm banana plugs, 6mm and 8mm (1/4 in and 5/16 in) spades, or bare wires up to 4mm (5/32 in) diameter.



Important Safety Notice

In certain countries, notably those in Europe, the use of 4mm banana plugs is considered a potential safety hazard, because they may be inserted into the holes of unshuttered mains supply sockets. In order to comply with European CENELEC safety regulations, the 4mm holes in the ends of the terminals are blocked by plastic pins. If you are using the products in any country where these conditions apply, you should ensure that any banana plugs cannot be used in an unsafe manner by children or other uninformed persons. The plastic pins can be removed if you wish to use banana plugs.

Ask your dealer for advice when selecting speaker cable. Keep its total impedance below the maximum recommended in the speaker specification and use a low inductance cable to avoid attenuation of high frequencies.

There are two pairs of terminals at the back of each speaker that enable bi-wiring (top). For single wire connection, fit the supplied link wires to join the like polarity terminals together. Bi-wiring can improve the resolution of low-level detail.

Ensure that the positive terminals on the speaker (with red ring) are connected to the positive output terminal on the amplifier and the negative terminals on the speaker (with black ring) are always connected to the negative output terminal on the amplifier. Incorrect connection will not result in damage but will cause poor stereo imaging and loss of bass. Always screw the terminal caps down fully to prevent rattles.

4. Fine Tuning and Running In

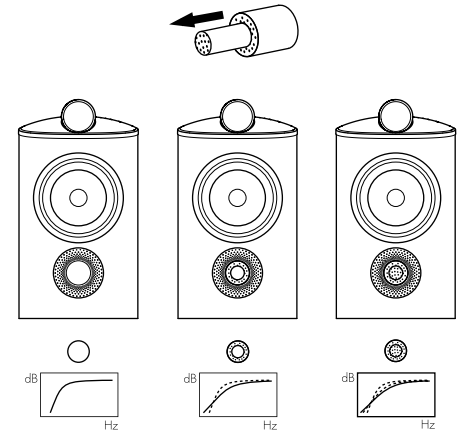

Before fine tuning, make sure that all the connections in the installation are correct and secure.

Moving the speakers further from the walls will generally reduce the volume of bass. Space behind the speakers will also help to create an aural impression of depth. Conversely, moving the speakers closer to the walls will increase the volume of bass. (805 D4 only) If you want to reduce the volume of bass without moving the speakers further from the wall, fit the foam plugs or, for less severe bass reduction, the foam rings in the port tubes (above).

If the bass seems uneven with frequency this will most probably be due to resonance modes in the listening room. Even small changes in the position of the speakers or the listening position can have a profound effect on how these resonances affect the sound. Try moving the listening position or locating the speakers along a different wall. The presence and position of large pieces of furniture can also influence resonance modes.

If the central image lacks focus, try moving the speakers closer together or angle them inward so that they point at a location just in front of the listening position.



Bowers & Wilkins

805 D4 Signature

Technical Information

**Technical features**

Diamond tweeter
 Solid Body Tweeter-on-Top
 Continuum™ cone bass/midrange
 Matrix™
 Anti-Resonance plug
 Flowport™

Description

2-way vented-box system

Drive units

1x ø25mm (1in) Diamond Dome high-frequency
 1x ø165mm (6.5in) Continuum™ cone bass/midrange

Frequency range

-6dB 34Hz to 35kHz

Frequency response

(+/-3dB from reference axis)

42Hz to 28kHz ±3dB

Sensitivity

(on axis at 2.83Vrms at 1m)

88dB

Harmonic distortion

2nd and 3rd harmonics (90dB, 1m on axis)

<1 % 90Hz - 20kHz

<0.3% 120Hz - 20kHz

Nominal impedance

8Ω (minimum 4.6Ω)

Recommended amplifier power

50W - 120W into 8Ω on unclipped programme

Max. recommended cable impedance

0.1Ω

Dimensions

Height: 440mm (17.3in)

Width: 240mm (9.4in)

Depth: 373mm (14.7in)

Net weight

15.6kg (34.3lbs)

Finishes

Cabinet: California Burl Gloss
 Midnight Blue Metallic

Grille: Black

